

## CT-1915619 SEAL KIT 105x150 mm

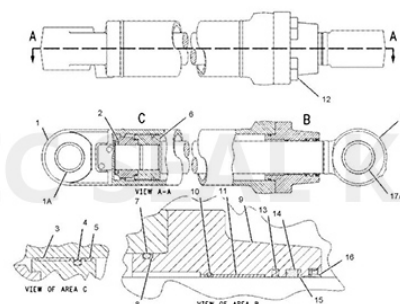

**Seal Kit equivalent to CATERPILLAR Part Number 1915619**

New OEM Aftermarket Seal Kit (Not branded CATERPILLAR, direct replacement). This seal kit is a high quality, direct replacement to original parts, at a fraction of the cost.

Hydraulic Cylinder Seal Kit Components			
Items	Brand	Material	Color
Rod Seals	NOK/SKF/H605/SPRS	Urethane (TPU)	Ivory/Blue/Gray
Buffer Seals	JSPSEAL/SPRS	Urethane+PA or PTFE Bronze+NBR	Ivory/Purple
Wipers	JSPSEAL/SPRS	Urethane+Metal or NBR+Metal	Ivory/Black
Piston Seals	JSPSEAL	PTFE Bronze+NBR+PA OR Nylon+NBR	Brown/Green/Gold
Wear Rings	JSPSEAL	Phenolic Resion Cotton Fabric or PTFE Bronze	Brown/Blue/Yellow
Backup Rings	JSPSEAL	PA or PTFE or PTFE Bronze	Black/White/Brown
O-Rings	JSPSEAL	NBR (Hardness 90 Shore A)	Black

### DESCRIPTION

? **Good quality seal parts** - Perfect Fit, More suitable for used machines

---

? **Factory direct sales** - Large quantity and best price

? **MOQ 1 set** - 5~7 days Delivery Time to any country

**Description of replacement Seal 1915619**

Used in the following applications:

**SERIAL NUMBER(s)** - Note: This kit applies to the following models, cylinders, and serial numbers. This kit may also apply to other models, cylinders, and serial numbers not currently listed below.

EXCAVATORS, 322C, BUCKET, CYL #: 1772465, SERIAL #: DAA1-UP; FED1-UP  
EXCAVATORS, 322C, BUCKET, CYL #: 2478853, SERIAL #: DAA1-UP; FED1-UP  
EXCAVATORS, 322C L, BUCKET, CYL #: 1772465, SERIAL #: BKJ1-UP; BKM1-UP; BLP1-UP; EMR1-UP; MAR1-UP  
EXCAVATORS, 322C L, BUCKET, CYL #: 2478853, SERIAL #: BKM1-UP; BLP1-UP  
EXCAVATORS, 322C L, STICK, CYL #: 2166607, SERIAL #: DAA1-UP; FED1-UP  
EXCAVATORS, 322C LN, BUCKET, CYL #: 1772465, SERIAL #: BFK1-UP; BGR1-UP; EMR1-UP; MAR1-UP  
EXCAVATORS, 322C LN, BUCKET, CYL #: 2478853, SERIAL #: BFK1-UP; BGR1-UP; EMR1-UP; MAR1-UP  
EXCAVATORS, 324D L, BUCKET, CYL #: 2254581, SERIAL #: JJG1-UP; SYM1-UP  
EXCAVATORS, 324D L, BUCKET, CYL #: 2898012, SERIAL #: JJG1-UP; LAB1-UP; SYM1-UP  
EXCAVATORS, 324D L, BUCKET, CYL #: 3154442, SERIAL #: DFP1-UP; JAT1-UP; PYT1-UP; SYM1-UP  
EXCAVATORS, 324D L, BUCKET, CYL #: 3154451, SERIAL #: BTK1-UP; JJG1-UP; LAB1-UP; PYT1-UP; SYM1-UP  
EXCAVATORS, 324D L, STICK, CYL #: 2166607, SERIAL #: DFP1-UP; JAT1-UP; JJG1-UP; PYT-UP  
EXCAVATORS, 325C, BOOM, CYL #: 1915548, SERIAL #: JLC1-UP; JLD1-UP  
EXCAVATORS, 325C, BOOM, CYL #: 2033906, SERIAL #: JLC1-UP  
EXCAVATORS, 325C, BUCKET, CYL #: 1772465, SERIAL #: AMH1-UP; BTD1-UP; JLC1-UP; JLD1-UP  
EXCAVATORS, 325C, BUCKET, CYL #: 2478853, SERIAL #: AMH1-UP; BTD1-UP; JLC1-UP; JLD1-UP  
EXCAVATORS, 325C, STICK, CYL #: 1799785, SERIAL #: JLC1-UP; JLD1-UP  
EXCAVATORS, 325C L, BOOM, CYL #: 1915548, SERIAL #: JLC1-UP; JLD1-UP  
EXCAVATORS, 325C L, BOOM, CYL #: 2033906, SERIAL #: JLC1-UP  
EXCAVATORS, 325C L, BUCKET, CYL #: 1772465, SERIAL #: AMH1-UP; BFE1-UP; BTD1-UP; CRB1-UP; CSJ1-UP; JLC1-UP; JLD1-UP  
EXCAVATORS, 325C L, BUCKET, CYL #: 2478853, SERIAL #: AMH1-UP; BTD1-UP; CRB1-UP; CSJ1-UP; JLC1-UP; JLD1-UP  
EXCAVATORS, 325C L, STICK, CYL #: 1799785, SERIAL #: CRB1-UP; CSJ1-UP; JLC1-UP; JLD1-UP  
EXCAVATORS, 325C LN, BUCKET, CYL #: 1772465, SERIAL #: CRB1-UP; CSJ1-UP  
EXCAVATORS, 325C LN, BUCKET, CYL #: 2478853, SERIAL #: CRB1-UP; CSJ1-UP  
EXCAVATORS, 325C LN, STICK, CYL #: 1799785, SERIAL #: CRB1-UP; CSJ1-UP  
EXCAVATORS, 325D, BUCKET, CYL #: 2254581, SERIAL #: AZP1-UP; DBH1-UP; KBE1-UP; KDG1-UP; SCR1-UP  
EXCAVATORS, 325D L, BOOM, CYL #: 2033906, SERIAL #: GBR1-UP

---

EXCAVATORS, 325D L, BUCKET, CYL #: 2254581, SERIAL #: A3R1-UP; AZP1-UP; DBH1-UP; GBR1-UP; GPB1-UP; KBE1-UP; KDG1-UP; MCL1-UP; PKE1-UP; SCR1-UP; T2S1-UP  
EXCAVATORS, 325D L, BUCKET, CYL #: 2898012, SERIAL #: A3R1-UP; GBR1-UP; GPB1-UP; LAL1-UP; MCL1-UP; NAC1-UP; PAL1-UP; PKE1-UP; T2S1-UP  
EXCAVATORS, 325D L, STICK, CYL #: 2166607, SERIAL #: A3R1-UP  
EXCAVATORS, 325D LN, BUCKET, CYL #: 2254581, SERIAL #: GPB1-UP; PKE1-UP  
EXCAVATORS, 325D LN, BUCKET, CYL #: 2898012, SERIAL #: GPB1-UP; PKE1-UP  
EXCAVATORS, 330C, BOOM, CYL #: 1915548, SERIAL #: GKX1-UP; JAB1-UP; JCD1-UP; JNK1-UP; KDD1-UP; MCA1-UP  
EXCAVATORS, 330C, BUCKET, CYL #: 1772465, SERIAL #: GKX1-UP; JAB1-UP; JCD1-UP; JNK1-UP; KDD1-UP; MCA1-UP  
EXCAVATORS, 330C, BUCKET, CYL #: 2478853, SERIAL #: GKX1-UP; JAB1-UP; JCD1-UP; JNK1-UP; KDD1-UP; MCA1-UP  
EXCAVATORS, 330C L, BOOM, CYL #: 1915548, SERIAL #: CAP1-UP; CGZ1-UP; GKX1-UP; JAB1-UP; JCD1-UP; JNK1-UP; KDD1-UP; MCA1-UP; MKM1-UP  
EXCAVATORS, 330C L, BUCKET, CYL #: 1772465, SERIAL #: CAP1-UP; CGZ1-UP; DKY1-UP; GKX1-UP; JAB1-UP; JCD1-UP; JNK1-UP; KDD1-UP; MCA1-UP; MKM1-UP  
EXCAVATORS, 330C L, BUCKET, CYL #: 2478853, SERIAL #: CAP1-UP; CGZ1-UP; GKX1-UP; JAB1-UP; JCD1-UP; JNK1-UP; KDD1-UP; MCA1-UP; MKM1-UP  
EXCAVATORS, 330C LN, BOOM, CYL #: 1915548, SERIAL #: CAP1-UP; CGZ1-UP  
EXCAVATORS, 330C LN, BUCKET, CYL #: 1772465, SERIAL #: CAP1-UP; CGZ1-UP  
EXCAVATORS, 330C LN, BUCKET, CYL #: 2478853, SERIAL #: CAP1-UP; CGZ1-UP  
EXCAVATORS, 330D, BUCKET, CYL #: 2254581, SERIAL #: EAH1-UP; EDX1-UP; ERN1-UP; FFK1-UP; MEY1-UP; NBD1-UP; THJ1-UP  
EXCAVATORS, 330D, BUCKET, CYL #: 2898012, SERIAL #: ERN1-UP; THJ1-UP  
EXCAVATORS, 330D L, BUCKET, CYL #: 2254581, SERIAL #: B6H1-UP; EAH1-UP; EDX1-UP; FFK1-UP; GGE1-UP; HAS1-UP; JLP1-UP; MAG1-UP; MEY1-UP; MWP1-UP; NBD1-UP; RAS1-UP; T2Y1-UP  
EXCAVATORS, 330D L, BUCKET, CYL #: 2898012, SERIAL #: B6H1-UP; GGE1-UP; HAS1-UP; JLP1-UP; LRM1-UP; MWP1-UP; RAS1-UP; T2Y1-UP  
EXCAVATORS, 330D N, BUCKET, CYL #: 2254581, SERIAL #: GGE1-UP; RAS1-UP  
EXCAVATORS, 330D N, BUCKET, CYL #: 2898012, SERIAL #: GGE1-UP; RAS1-UP  
EXCAVATORS, 336D, BUCKET, CYL #: 3154442, SERIAL #: JBT1-UP; KKT1-UP; PGW1-UP  
EXCAVATORS, 336D, BUCKET, CYL #: 3154451, SERIAL #: KKT1-UP; MYG1-UP; MYP1-UP; PGW1-UP  
EXCAVATORS, 336D L, BUCKET, CYL #: 2898012, SERIAL #: J2F1-UP; M4T1-UP  
EXCAVATORS, 336D L, BUCKET, CYL #: 3154442, SERIAL #: MPL1-UP; PRF1-UP; WRK1-UP  
EXCAVATORS, 336D L, BUCKET, CYL #: 3154451, SERIAL #: DTS1-UP; J2F1-UP; JBF1-UP; JWR1-UP; KDJ1-UP; LMG1-UP; PPN1-UP; PRF1-UP; PTB1-UP; WET1-UP; W3K1-UP; WRK1-UP; ZML1-UP

**MISCELLANEOUS INFORMATION** – Note: Some of the miscellaneous information is model specific. For this reason, all miscellaneous information is presented by make, model, etc.

EXCAVATORS, 325C, STICK, CYL #: 1799785, MISC INFO: Type 1  
EXCAVATORS, 325C L, STICK, CYL #: 1799785, MISC INFO: Type 1  
EXCAVATORS, 325C LN, STICK, CYL #: 1799785, MISC INFO: Type 1

*\*All manufacturer's names, part numbers and descriptions are used for reference purposes only. We do not imply that any part shown is the product of these manufacturers. We also do not imply that the*

---

*list price shown is exactly that of the manufacturer.*

### Shipping Guide

- 1.All prices are based on EXW prices, have not including shipping cost
- 2.Small order and Sample order ship by air or Express (DHL, TNT, EMS),Freight Collect
- 3.General Order ship by sea or air.

### Payment:

1. For small order, payment on line by Paypal/Western Union
2. T/T to our company bank account

## Why choose JSPSEAL seal kits part?

**1.Experience.** We have been selling in the aftermarket for nearly 20 years, we know more about what kind of seal kits the machine needs under bad work conditions.

**2.The accuracy of the dimensions.**The same part number as the OEM, easy to query and purchase.

**3.Price.** We can beat all OEM parts in value, while as stated above the quality of the parts will remain the same.

**4.Lead Times.** JSPSEAL products have been exported for more than 10 years, and our extensive export experience can help you solve various transportation problems. We can ensure fast and efficient lead times across all JSPSEAL Parts.

## How to find seal kit part number and send us an inquiry ?

To find the exact part for your machine, the best way to do it is to find out the part number you need, and then search it in our search bar on our homepage, [www.jspseal.com](http://www.jspseal.com). This will show you the right part for what you need, and you can order quickly without fuss.

However, if you can't find the part you need please [contact us](#) and we will source it for you.

More seal kits catalog download: <https://www.jspseal.com/catalogs/>

---

Product link : <https://www.jspseal.com/ct-1915619-seal-kit-90x130-mm.html>